



Serrature di sicurezza per montanti

Vertical security locks pag. 265

Serrature multipunto per montanti

Vertical multi-point locks pag. 278

Accessori per chiusure supplementari

Accessories for additional locking points pag. 286

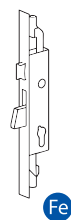

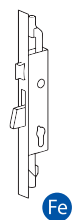

Serrature di sicurezza per montanti

Vertical security locks



PROGETTATA E TESTATA SECONDO LA NORMA EUROPEA EN 12209:05
 DESIGNED AND TESTED ACCORDING TO EUROPEAN STANDARD EN 12209:05

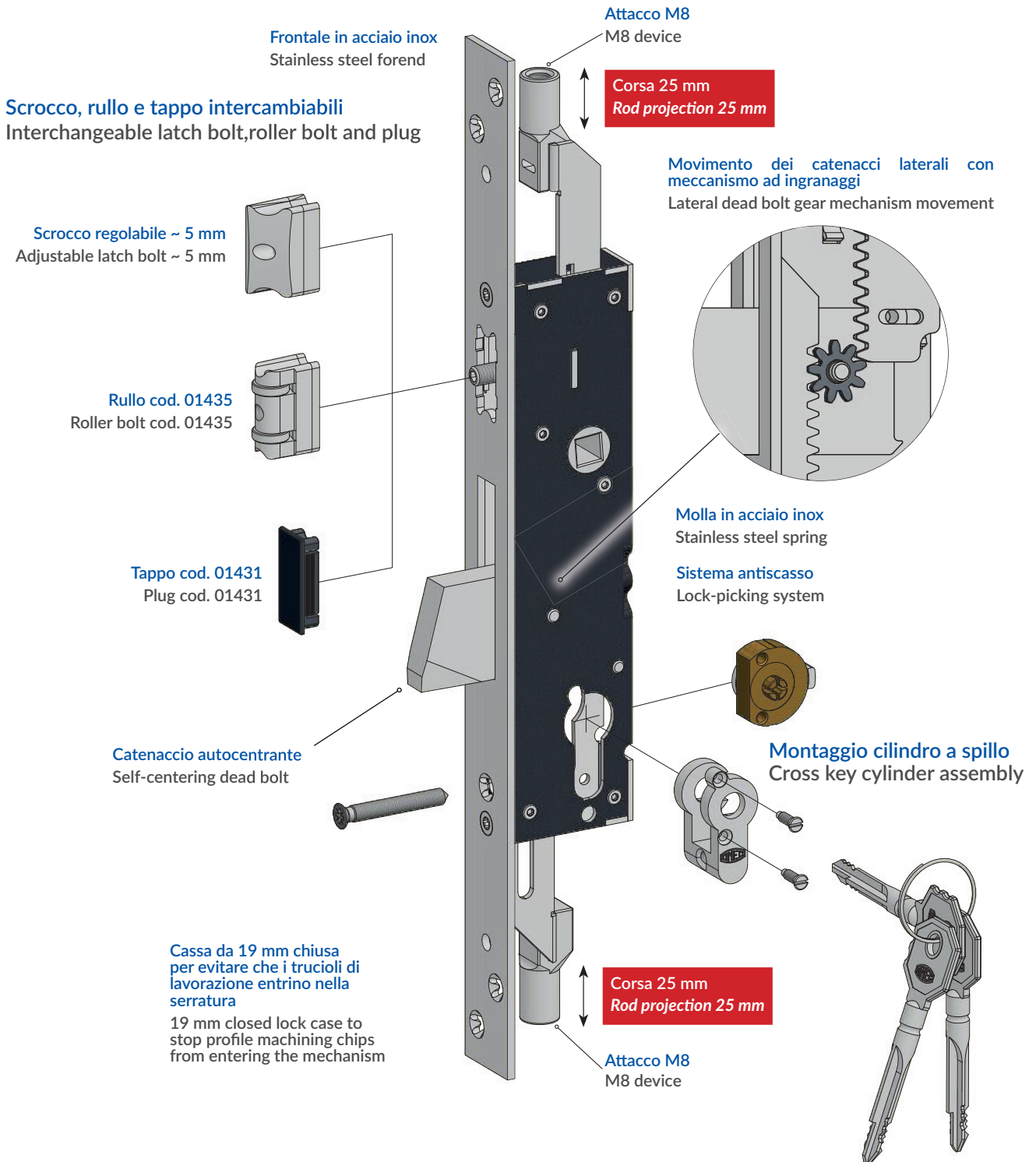

Il movimento maggiorato dei catenacci laterali (25 mm) permette un migliore inserimento dei puntali delle aste nel telaio del serramento, assicurando l'efficacia delle chiusure alto e basso.
 Longer rod projection (25 mm) allows a better fitting of dead bolts in the profile, ensuring a safer and more effective locking.

Cilindro a spillo cod. 4052 o 4052/1 con chiavi lunghe (tranne cod. 1473)
 Cross key cylinder cod. 4052 or 4052/1 with long keys (but cod. 1473)

Serrature di sicurezza per montanti

Vertical security locks



Catenaccio e scrocco regolabile 3 punti di chiusura - Dead and adjustable latch bolt 3 locking points

Scrocco intercambiabile con rullo cod. 01435 - Latch bolt interchangeable into roller bolt cod. 01435

Con attacchi M8 - Provided with M8 devices

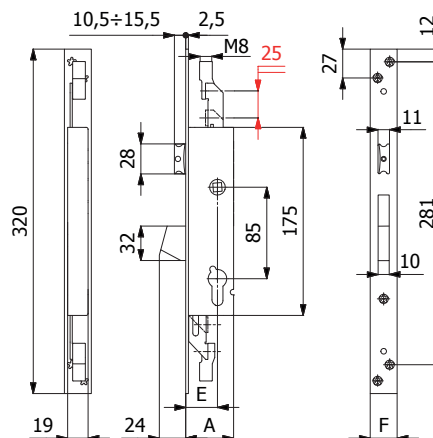

CARATTERISTICHE COSTRUTTIVE: Scatola e coperchio in acciaio zincato e plastificato - Frontale in acciaio inox - Catenaccio autocentrante in lega speciale cromata con sistema antiscasso - Scrocco in lega speciale cromata - Ingegno maniglia in lega speciale zincata foro \varnothing 8 mm.

FUNZIONAMENTO: Catenaccio comandato dalla chiave - Scrocco comandato dalla chiave o dalla maniglia.

MANO: Reversibile.

PARTI IN DOTAZIONE: Viti di fissaggio

Per serie 1490: 1 borchia cod. 0120 N, vite cilindro.

Per serie 4490: Cilindro a spillo cod. 4052 o 4052/1 (chiavi lunghe), 3 chiavi, 2 borchie cod. 0441 N.

CONFEZIONAMENTO: Imballo singolo in cellophane.

CONSTRUCTIVE FEATURES: Zinc and plastic plated steel case and cover - Stainless steel forend - Chromed special alloy self-centering dead bolt with lock-picking system - Chromed special alloy latch bolt - Zinc-plated special alloy square spindle device \varnothing 8 mm.

WORKING: Key driven dead bolt - Handle or key driven latch bolt.

HAND: Reversible.

PROVIDED WITH: Fixing screws

For locks 1490: 1 rose cod. 0120 N, cylinder screw.

For locks 4490: Cross key cylinder cod. 4052 or 4052/1 (long keys), 3 keys, 2 roses cod. 0441 N

PACKAGING: Single cellophane pack.

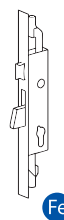

Fe

| COD. | E | F | A | mandate throws | cilindro cylinder | chiave key | kg | | |
|-------------------|----|----|----|-------------------|----------------------|---------------|-------|----|---|
| 1490.25.25.M8.E | 25 | 25 | 40 | 1 | | - | 0,64 | 30 | - |
| 1490.30.25.M8.E | 30 | 25 | 45 | 1 | | 0,66 | 30 | - | |
| 1490.35.25.M8.E | 35 | 25 | 50 | 1 | | 0,69 | 30 | - | |
| 4490.25.25.M8.E | 25 | 25 | 40 | 1 | cod. 4052 | cod. 4100 | 0,72 | 30 | - |
| 4490.30.25.M8.E | 30 | 25 | 45 | 1 | | | 0,74 | 30 | - |
| 4490.35.25.M8.E | 35 | 25 | 50 | 1 | | | 0,77 | 30 | - |
| 4490/1.**.25.M8.E | - | - | - | - | cod. 4052/1 | cod.4101 | +0,02 | - | - |

Serrature di sicurezza per montanti

Vertical security locks



Catenaccio 3 punti di chiusura - Dead bolt 3 locking points

Con attacchi M8 - Provided with M8 devices

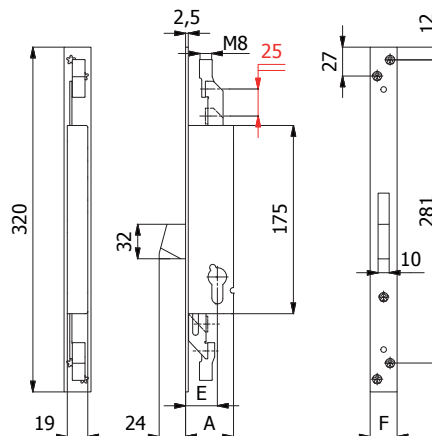
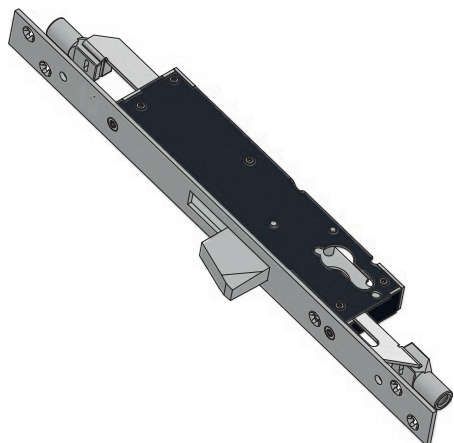

CARATTERISTICHE COSTRUTTIVE: Scatola e coperchio in acciaio zincato e plastificato - Frontale in acciaio inox - Catenaccio autocentrante in lega speciale cromata con sistema antiscasso.

FUNZIONAMENTO: Catenaccio comandato dalla chiave.

MANO: Unica.

PARTI IN DOTAZIONE: Viti di fissaggio

Per serie 1491: 1 borchia cod. 0120 N, vite cilindro.

Per serie 4491: Cilindro a spillo cod. 4052 o 4052/1 (chiavi lunghe), 3 chiavi, 2 borchie cod. 0441 N.

CONFEZIONAMENTO: Imballo singolo in cellophane.

CONSTRUCTIVE FEATURES: Zinc and plastic plated steel case and cover - Stainless steel forend - Chromed special alloy self-centering dead bolt with lock-picking system.

WORKING: Key driven dead bolt .

HAND: No hand.

PROVIDED WITH: Fixing screws

For locks 1491: 1 rose cod. 0120 N, cylinder screw.

For locks 4491: Cross key cylinder cod. 4052 or 4052/1 (long keys), 3 keys, 2 roses cod. 0441 N.

PACKAGING: Single cellophane pack.

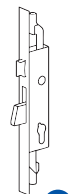

Fe

| COD. | E | F | A | mandate throws | cilindro cylinder | chiave key | kg | | |
|-------------------|----|----|----|-------------------|----------------------|---------------|-------|----|---|
| 1491.25.25.M8.E | 25 | 25 | 40 | 1 | | - | 0,58 | 30 | - |
| 1491.30.25.M8.E | 30 | 25 | 45 | 1 | | 0,60 | 30 | - | |
| 1491.35.25.M8.E | 35 | 25 | 50 | 1 | | 0,63 | 30 | - | |
| 4491.25.25.M8.E | 25 | 25 | 40 | 1 | cod. 4052 | cod. 4100 | 0,66 | 30 | - |
| 4491.30.25.M8.E | 30 | 25 | 45 | 1 | | | 0,68 | 30 | - |
| 4491.35.25.M8.E | 35 | 25 | 50 | 1 | | | 0,71 | 30 | - |
| 4491/1.**.25.M8.E | - | - | - | - | cod. 4052/1 | cod.4101 | +0,02 | - | - |

Serrature di sicurezza per montanti

Vertical security locks



Catenaccio con maniglia 3 punti di chiusura - Dead bolt with handle 3 locking points

Con attacchi M8 - Provided with M8 devices

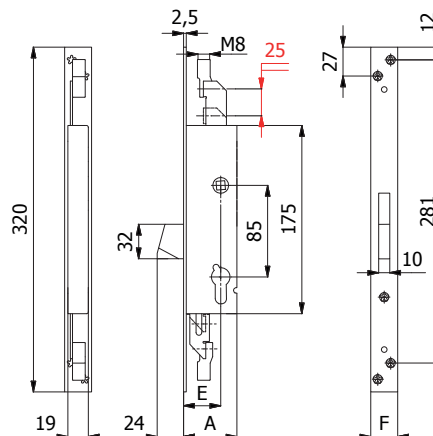

CARATTERISTICHE COSTRUTTIVE: Scatola e coperchio in acciaio zincato e plastificato - Frontale in acciaio inox - Catenaccio autocentrante in lega speciale cromata con sistema antiscasso - Ingegno maniglia in lega speciale zincata foro \varnothing 8 mm.

FUNZIONAMENTO: Catenaccio comandato dalla maniglia - Blocco maniglia comandato dalla chiave.

MANO: Unica.

PARTI IN DOTAZIONE: Viti di fissaggio

Per serie 1491Q: 1 borchia cod. 0120 N, vite cilindro.

Per serie 4491Q: Cilindro a spillo cod. 4052 o 4052/1 (chiavi lunghe) , 3 chiavi, 2 borchie cod. 0441 N.

CONFEZIONAMENTO: Imballo singolo in cellophane.

CONSTRUCTIVE FEATURES: Zinc and plastic plated steel case and cover - Stainless steel forend - Chromed special alloy self-centering dead bolt with lock-picking system - Zinc-plated special alloy square spindle device \varnothing 8 mm.

WORKING: Handle driven dead bolt - Key driven handle interlock.

HAND: No hand.

PROVIDED WITH: Fixing screws

For locks 1491Q: 1 rose cod. 0120 N, cylinder screw.

For locks 4491Q: Cross key cylinder cod. 4052 or 4052/1 (long keys), 3 keys, 2 roses cod. 0441 N.

PACKAGING: Single cellophane pack.

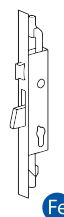

Fe

| COD. | E | F | A | mandate throws | cilindro cylinder | chiave key | kg | | |
|--------------------|----|----|----|-------------------|----------------------|---------------|-------|----|---|
| 1491Q.25.25.M8.E | 25 | 25 | 40 | 1 | | - | 0,68 | 30 | - |
| 1491Q.30.25.M8.E | 30 | 25 | 45 | 1 | | 0,71 | 30 | - | |
| 1491Q.35.25.M8.E | 35 | 25 | 50 | 1 | | 0,74 | 30 | - | |
| 4491Q.25.25.M8.E | 25 | 25 | 40 | 1 | cod. 4052 | cod. 4100 | 0,76 | 30 | - |
| 4491Q.30.25.M8.E | 30 | 25 | 45 | 1 | | | 0,79 | 30 | - |
| 4491Q.35.25.M8.E | 35 | 25 | 50 | 1 | | | 0,82 | 30 | - |
| 4491Q/1.**.25.M8.E | - | - | - | - | cod. 4052/1 | cod.4101 | +0,02 | - | - |

Serrature di sicurezza per montanti Vertical security locks



Catenaccio e rullo regolabile 3 punti di chiusura - Dead and adjustable roller bolt 3 locking points

Con attacchi M8 - Provided with M8 devices

AD ESAURIMENTO
END OF LINE

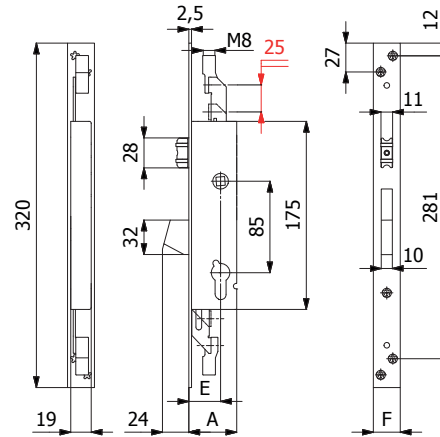

CARATTERISTICHE COSTRUTTIVE: Scatola e coperchio in acciaio zincato e plastificato - Frontale in acciaio inox - Catenaccio autocentrante in lega speciale cromata con sistema antiscasso - Rullo in ottone cromato.

FUNZIONAMENTO: Catenaccio comandato dalla chiave - Rullo comandato a pressione o dalla chiave.

MANO: Unica.

PARTI IN DOTAZIONE: Viti di fissaggio

Per serie 1495: 1 borchia cod. 0120 N, vite cilindro.

Per serie 4495: Cilindro a spillo cod. 4052 o 4052/1 (chiavi lunghe), 3 chiavi, 2 borchie cod. 0441 N.

CONFEZIONAMENTO: Imballo singolo in cellophane.

CONSTRUCTIVE FEATURES: Zinc and plastic plated steel case and cover - Stainless steel forend - Chromed special alloy self-centering dead bolt with lock-picking system - Chromed brass roller bolt.

WORKING: Key driven dead bolt - Pressure or key driven roller bolt.

HAND: No hand.

PROVIDED WITH: Fixing screws

For locks 1495: 1 rose cod. 0120 N, cylinder screw.

For locks 4495: Cross key cylinder cod. 4052 or 4052/1 (long keys), 3 keys, 2 roses cod. 0441 N.

PACKAGING: Single cellophane pack.

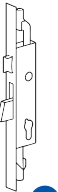

Fe

| COD. | E | F | A | mandate throws | cilindro cylinder | chiave key | kg | | |
|-------------------|----|----|----|-------------------|----------------------|---------------|-------|----|---|
| 1495.25.25.M8.E | 25 | 25 | 40 | 1 | | - | 0,64 | 30 | - |
| 1495.30.25.M8.E | 30 | 25 | 45 | 1 | | 0,66 | 30 | - | |
| 1495.35.25.M8.E | 35 | 25 | 50 | 1 | | 0,69 | 30 | - | |
| 4495.25.25.M8.E | 25 | 25 | 40 | 1 | cod. 4052 | cod. 4100 | 0,72 | 30 | - |
| 4495.30.25.M8.E | 30 | 25 | 45 | 1 | | | 0,74 | 30 | - |
| 4495.35.25.M8.E | 35 | 25 | 50 | 1 | | | 0,77 | 30 | - |
| 4495/1.**.25.M8.E | - | - | - | - | cod. 4052/1 | cod.4101 | +0,02 | - | - |

Serrature di sicurezza per montanti Vertical security locks



Gancio 3 punti di chiusura - Hook bolt 3 locking points

Con attacchi M8 - Provided with M8 devices

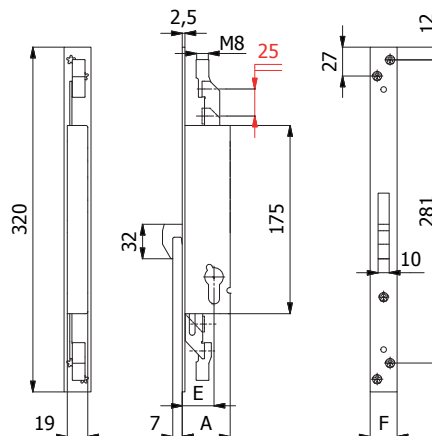
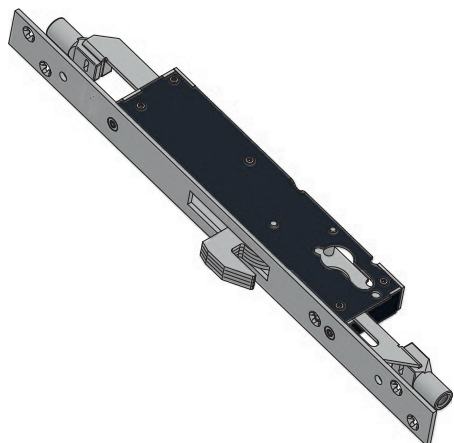

CARATTERISTICHE COSTRUTTIVE: Scatola e coperchio in acciaio zincato e plastificato - Frontale in acciaio inox - Gancio in acciaio inox.

FUNZIONAMENTO: Gancio comandato dalla chiave.

MANO: Unica.

PARTI IN DOTAZIONE: Viti di fissaggio

Per serie 1496: 1 borchia cod. 0120 N, vite cilindro.

Per serie 4496: Cilindro a spillo cod. 4052 o 4052/1 (chiavi lunghe), 3 chiavi, 2 borchie cod. 0441 N.

CONFEZIONAMENTO: Imballo singolo in cellophane.

CONSTRUCTIVE FEATURES: Zinc and plastic plated steel case and cover - Stainless steel forend - Stainless steel hook bolt.

WORKING: Key driven hook bolt.

HAND: No hand.

PROVIDED WITH: Fixing screws

For locks 1496: 1 rose cod. 0120 N, cylinder screw.

For locks 4496: Cross key cylinder cod. 4052 or 4052/1 (long keys), 3 keys, 2 roses cod. 0441 N.

PACKAGING: Single cellophane pack.

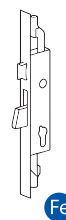

Fe

| COD. | E | F | A | mandate throws | cilindro cylinder | chiave key | kg | | |
|-------------------|----|----|----|-------------------|----------------------|---------------|-------|----|---|
| 1496.25.25.M8.E | 25 | 25 | 40 | 1 | | - | 0,61 | 30 | - |
| 1496.30.25.M8.E | 30 | 25 | 45 | 1 | | 0,64 | 30 | - | |
| 1496.35.25.M8.E | 35 | 25 | 50 | 1 | | 0,65 | 30 | - | |
| 4496.25.25.M8.E | 25 | 25 | 40 | 1 | cod. 4052 | cod. 4100 | 0,69 | 30 | - |
| 4496.30.25.M8.E | 30 | 25 | 45 | 1 | | | 0,72 | 30 | - |
| 4496.35.25.M8.E | 35 | 25 | 50 | 1 | | | 0,73 | 30 | - |
| 4496/1.**.25.M8.E | - | - | - | - | cod. 4052/1 | cod.4101 | +0,02 | - | - |

Serrature di sicurezza per montanti Vertical security locks



Gancio con maniglia 3 punti di chiusura - Hook bolt with handle 3 locking points

Con attacchi M8 - Provided with M8 devices

NEW

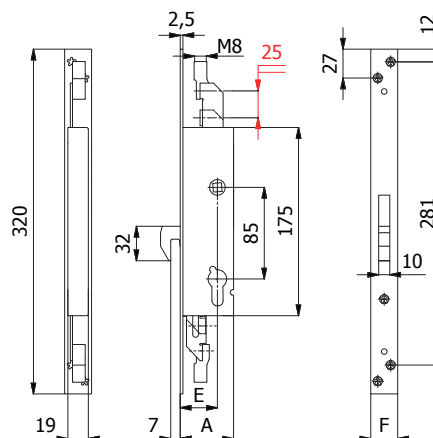

CARATTERISTICHE COSTRUTTIVE: Scatola e coperchio in acciaio zincato e plastificato - Frontale in acciaio inox - Gancio in acciaio inox - Ingegno maniglia in lega speciale zincata foro \varnothing 8 mm.

FUNZIONAMENTO: Gancio comandato dalla maniglia - Blocco maniglia comandato dalla chiave.

MANO: Unica.

PARTI IN DOTAZIONE: Viti di fissaggio

Per serie 1496Q: 1 borchia cod. 0120 N, vite cilindro.

Per serie 4496Q: Cilindro a spillo cod. 4052 o 4052/1 (chiavi lunghe) , 3 chiavi, 2 borchie cod. 0441 N.

CONFEZIONAMENTO: Imballo singolo in cellophane.

CONSTRUCTIVE FEATURES: Zinc and plastic plated steel case and cover - Stainless steel forend - Stainless steel hook bolt - Zinc-plated special alloy square spindle device \varnothing 8 mm.

WORKING: Handle driven hook bolt - Key driven handle interlock.

HAND: No hand.

PROVIDED WITH: Fixing screws

For locks 1496Q: 1 rose cod. 0120 N, cylinder screw.

For locks 4496Q: Cross key cylinder cod. 4052 or 4052/1 (long keys), 3 keys, 2 roses cod. 0441 N.

PACKAGING: Single cellophane pack.

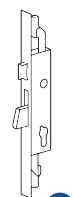

Fe

| COD. | E | F | A | mandate throws | cilindro cylinder | chiave key | kg | | |
|--------------------|----|----|----|-------------------|----------------------|---------------|-------|----|---|
| 1496Q.25.25.M8.E | 25 | 25 | 40 | 1 | | - | 0,71 | 30 | - |
| 1496Q.30.25.M8.E | 30 | 25 | 45 | 1 | | 0,74 | 30 | - | |
| 1496Q.35.25.M8.E | 35 | 25 | 50 | 1 | | 0,75 | 30 | - | |
| 4496Q.25.25.M8.E | 25 | 25 | 40 | 1 | cod. 4052 | cod. 4100 | 0,79 | 30 | - |
| 4496Q.30.25.M8.E | 30 | 25 | 45 | 1 | | | 0,72 | 30 | - |
| 4496Q.35.25.M8.E | 35 | 25 | 50 | 1 | | | 0,73 | 30 | - |
| 4496Q/1.**.25.M8.E | - | - | - | - | cod. 4052/1 | cod.4101 | +0,02 | - | - |

Serrature di sicurezza per montanti Vertical security locks



Alto e basso 2 punti di chiusura - Top and bottom 2 locking points

Con attacchi M8 - Provided with M8 devices

NEW

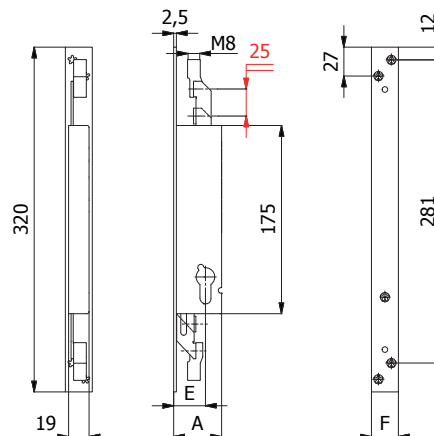
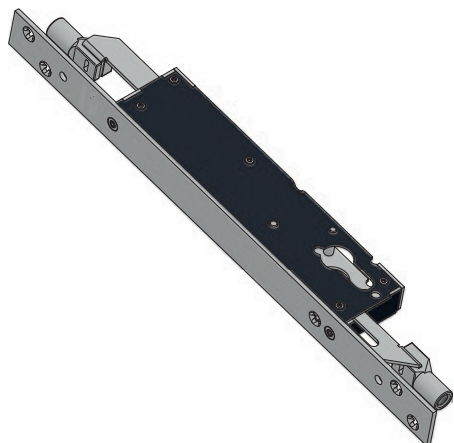

CARATTERISTICHE COSTRUTTIVE: Scatola e coperchio in acciaio zincato e plastificato - Frontale in acciaio inox.

FUNZIONAMENTO: Aste verticali comandate dalla chiave.

MANO: Unica.

PARTI IN DOTAZIONE: Viti di fissaggio

Per serie 1492: 1 borchia cod. 0120 N, vite cilindro.

Per serie 4492: Cilindro a spillo cod. 4052 o 4052/1 (chiavi lunghe), 3 chiavi, 2 borchie cod. 0441 N.

CONFEZIONAMENTO: Imballo singolo in cellophane.

CONSTRUCTIVE FEATURES: Zinc and plastic plated steel case and cover - Stainless steel forend.

WORKING: Key driven vertical rods.

HAND: No hand.

PROVIDED WITH: Fixing screws

For locks 1492: 1 rose cod. 0120 N, cylinder screw.

For locks 4492: Cross key cylinder cod. 4052 or 4052/1 (long keys), 3 keys, 2 roses cod. 0441 N.

PACKAGING: Single cellophane pack.

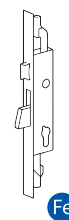

Fe

| COD. | E | F | A | mandate throws | cilindro cylinder | chiave key | kg | | |
|-------------------|------|----|----|-------------------|----------------------|---------------|-------|----|---|
| 1492.23.25.M8.E | 22,5 | 25 | 37 | 1 | | | 0,57 | 30 | - |
| 1492.25.25.M8.E | 25 | 25 | 40 | 1 | | - | 0,58 | 30 | - |
| 1492.30.25.M8.E | 30 | 25 | 45 | 1 | | | 0,60 | 30 | - |
| 1492.35.25.M8.E | 35 | 25 | 50 | 1 | | | 0,63 | 30 | - |
| 4492.23.25.M8.E | 22,5 | 25 | 37 | 1 | | | 0,65 | 30 | - |
| 4492.25.25.M8.E | 25 | 25 | 40 | 1 | cod. 4052 | cod. 4100 | 0,66 | 30 | - |
| 4492.30.25.M8.E | 30 | 25 | 45 | 1 | | | 0,68 | 30 | - |
| 4492.35.25.M8.E | 35 | 25 | 50 | 1 | | | 0,71 | 30 | - |
| 4492/1.**.25.M8.E | - | - | - | - | cod. 4052/1 | cod.4101 | +0,02 | - | - |

Serrature di sicurezza per montanti Vertical security locks



Alto e basso con maniglia 2 punti di chiusura - Top and bottom with handle 2 locking points
Con attacchi M8 - Provided with M8 devices

NEW

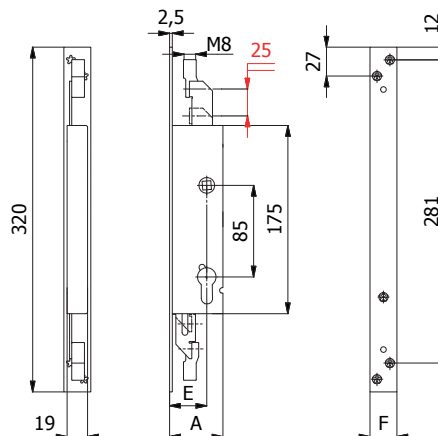

CARATTERISTICHE COSTRUTTIVE: Scatola e coperchio in acciaio zincato e plastificato - Frontale in acciaio inox - Ingegno maniglia in lega speciale zincata foro \varnothing 8 mm.

FUNZIONAMENTO: Aste verticali comandate dalla maniglia - Blocco maniglia comandato dalla chiave.

MANO: Unica.

PARTI IN DOTAZIONE: Viti di fissaggio

Per serie 1492Q: 1 borchia cod. 0120 N, vite cilindro.

Per serie 4492Q: Cilindro a spillo cod. 4052 o 4052/1 (chiavi lunghe), 3 chiavi, 2 borchie cod. 0441 N.

CONFEZIONAMENTO: Imballo singolo in cellophane.

CONSTRUCTIVE FEATURES: Zinc and plastic plated steel case and cover - Stainless steel forend - Zinc-plated special alloy square spindle device \varnothing 8 mm.

WORKING: Handle driven vertical rods - Key driven handle interlock.

HAND: No hand.

PROVIDED WITH: Fixing screws

For locks 1492Q: 1 rose cod. 0120 N, cylinder screw.

For locks 4492Q: Cross key cylinder cod. 4052 or 4052/1 (long keys), 3 keys, 2 roses cod. 0441 N.

PACKAGING: Single cellophane pack.

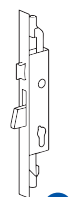

Fe

| COD. | E | F | A | mandate throws | cilindro cylinder | chiave key | kg | | |
|--------------------|----|----|----|-------------------|----------------------|---------------|-------|----|---|
| 1492Q.25.25.M8.E | 25 | 25 | 40 | 1 | | | 0,59 | 30 | - |
| 1492Q.30.25.M8.E | 30 | 25 | 45 | 1 | | - | 0,62 | 30 | - |
| 1492Q.35.25.M8.E | 35 | 25 | 50 | 1 | | | 0,64 | 30 | - |
| 4492Q.25.25.M8.E | 25 | 25 | 40 | 1 | cod. 4052 | cod. 4100 | 0,67 | 30 | - |
| 4492Q.30.25.M8.E | 30 | 25 | 45 | 1 | | | 0,70 | 30 | - |
| 4492Q.35.25.M8.E | 35 | 25 | 50 | 1 | | | 0,72 | 30 | - |
| 4492Q/1.**.25.M8.E | - | - | - | - | cod. 4052/1 | cod.4101 | +0,02 | - | - |



Gancio con maniglia 3 punti di chiusura - Hook bolt with handle 3 locking points

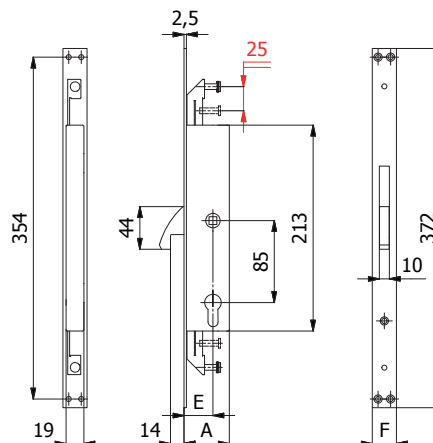

CARATTERISTICHE COSTRUTTIVE: Scatola e coperchio in acciaio zincato e plastificato - Frontale in acciaio inox - Gancio in acciaio cromato - Ingegno maniglia in acciaio brunito foro \varnothing 8 mm

FUNZIONAMENTO: Gancio comandato dalla maniglia - Blocco maniglia comandato dalla chiave.

MANO: Unica.

PARTI IN DOTAZIONE: Viti di fissaggio in acciaio inox

Per serie 1473: 2 borchie cod. 0120 N, vite cilindro

Per serie 4473: Cilindro a spillo cod. 4072 o 4072/1 (con chiavi lunghe), 3 chiavi, 2 borchie cod. 0441 N

CONSTRUCTIVE FEATURES: Zinc and plastic plated steel case and cover - Stainless steel forend - Chromed steel hook bolt - Burnished steel square spindle device \varnothing 8 mm

WORKING: Handle driven hook bolt - Key driven handle interlock.

HAND: No hand.

PROVIDED WITH: Stainless steel fixing screws

For series 1473: 2 roses cod.0120 N, cylinder screw

For series 4473: Cross key cylinder cod.4072 or 4072/1 (with long keys), 2 keys, 2 roses cod.0441 N

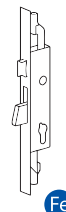

Fe

| COD. | E | F | A | mandate throws | cilindro cylinder | chiave key | kg | | |
|--------|----|----|----|-------------------|----------------------|---------------|--------|---|---|
| 1473 | 30 | 25 | 47 | 1 | | - | 0,80 | 1 | - |
| 4473 | 30 | 25 | 47 | 1 | cod. 4072 | cod. 4100 | 0,88 | 1 | - |
| 4473/1 | - | - | - | - | cod. 4072/1 | cod. 4101 | + 0,02 | - | - |

Serrature di sicurezza per montanti Vertical security locks



Gancio con maniglia 3 punti di chiusura - Hook bolt with handle 3 locking points

Con attacchi M8 - Provided with M8 devices

NEW

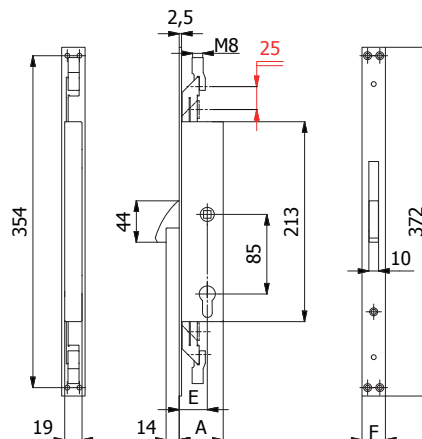
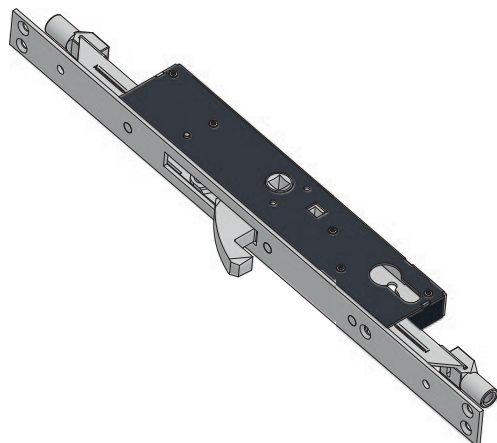

CARATTERISTICHE COSTRUTTIVE: Scatola e coperchio in acciaio zincato e plastificato - Frontale in acciaio inox - Gancio in acciaio cromato - Ingegno maniglia in acciaio brunito foro \varnothing 8 mm

FUNZIONAMENTO: Gancio comandato dalla maniglia - Blocco maniglia comandato dalla chiave.

MANO: Unica.

PARTI IN DOTAZIONE:

Per serie 1473 EM8: 1 borchia cod. 0120 N, vite cilindro

Per serie 4473 EM8: Cilindro a spillo cod. 4072 o 4072/1 (con chiavi lunghe), 3 chiavi, 2 borchie cod. 0441 N

CONFEZIONAMENTO: Imballo singolo in cellophane.

CONSTRUCTIVE FEATURES: Zinc and plastic plated steel case and cover - Stainless steel forend - Chromed steel hook bolt - Burnished steel square spindle device \varnothing 8 mm

WORKING: Handle driven hook bolt - Key driven handle interlock.

HAND: No hand.

PROVIDED WITH:

For series 1473 EM8: 1 rose cod.0120 N, cylinder screw

For series 4473 EM8: Cross key cylinder cod.4072 or 4072/1 (with long keys), 2 keys, 2 roses cod.0441 N

PACKAGING: Single cellophane pack.

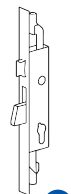

Fe

| COD. | E | F | A | mandate throws | cilindro cylinder | chiave key | kg | | |
|------------|----|----|----|-------------------|----------------------|---------------|--------|----|---|
| 1473 EM8 | 30 | 25 | 47 | 1 | | - | 0,80 | 30 | - |
| 4473 EM8 | 30 | 25 | 47 | 1 | cod. 4072 | cod. 4100 | 0,88 | 30 | - |
| 4473 EM8/1 | - | - | - | - | cod. 4072/1 | cod. 4101 | + 0,02 | - | - |

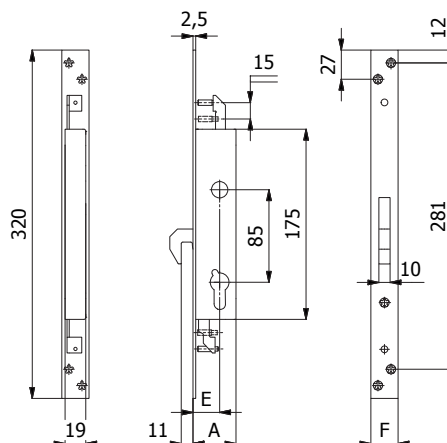

CARATTERISTICHE COSTRUTTIVE: Scatola e coperchio in acciaio zincato e plastificato - Frontale in acciaio inox - Gancio in acciaio inox.

FUNZIONAMENTO: Gancio comandato dalla chiave.

MANO: Unica.

PARTI IN DOTAZIONE: Viti di fissaggio

Per serie 1466 P1: vite cilindro.

Per serie 4466 P1: Cilindro a spillo cod. 4052 o 4052/1 (chiavi lunghe), 3 chiavi, 2 borchie cod. 0441 N.

CONFEZIONAMENTO: Imballo singolo in cellophane.

CONSTRUCTIVE FEATURES: Zinc and plastic plated steel case and cover - Stainless steel forend - Stainless steel hook bolt.

WORKING: Key driven hook bolt.

HAND: No hand.

PROVIDED WITH: Fixing screws

For locks 1466 P1: cylinder screw.

For locks 4466 P1: Cross key cylinder cod. 4052 or 4052/1 (long keys), 3 keys, 2 roses cod. 0441 N.

PACKAGING: Single cellophane pack.

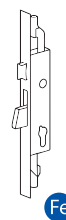

Fe

| COD. | E | F | A | mandate throws | cilindro cylinder | chiave key | kg | | |
|-----------|----|----|----|-------------------|----------------------|---------------|-------|----|---|
| 1466 P1 | 25 | 25 | 40 | 1 | | - | 0,52 | 30 | - |
| 4466 P1 | 25 | 25 | 40 | 1 | cod. 4052 | cod. 4100 | 0,60 | 30 | - |
| 4466 P1/1 | - | - | - | - | cod. 4052/1 | cod.4101 | +0,02 | - | - |

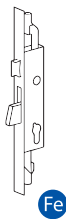

Serrature multipunto per montanti

Vertical multi-point locks



PROGETTATA E TESTATA SECONDO IL PROGETTO DI NORMA EUROPEA prEN 15685:10
 DESIGNED AND TESTED ACCORDING TO THE DRAFT OF EUROPEAN STANDARD prEN 15685:10

Scrocco e tappo intercambiabili

Interchangeable latch bolt and plug

Scrocco regolabile ~ 5 mm
 Adjustable latch bolt ~ 5 mm

Rullo cod.01435
 Roller bolt cod.01435

Tappo cod. 01431
 Plug cod. 01431

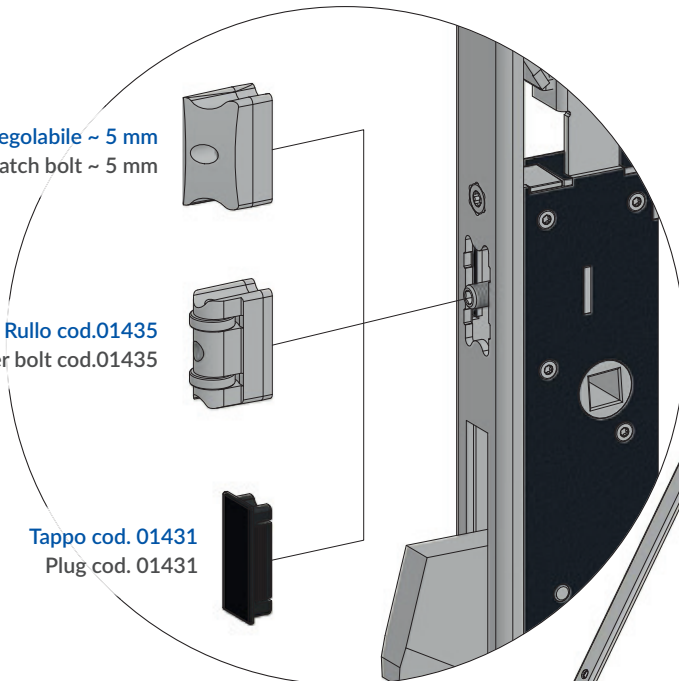

Attacco M8
 M8 Device

Cassa della serratura e dei deviatori da 19 mm chiusa per evitare che trucioli di lavorazione entrino nella serratura
 19 mm closed lockcases to stop profile machining chips from entering into the lock

Frontale, aste di trascinamento, rinvii aste e molle in acciaio inox
 Stainless steel faceplate, rods, additional locking point devices and springs

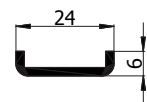

Catenacci basculanti autocentranti in lega speciale cromata con spessore 10 mm, escursione 24 mm

Catenaccio con sistema anticasso per massimizzare la resistenza all'effrazione

Chrome special-alloy tipping dead bolts, thickness 10 mm, excursion 24 mm

Lock picking system dead bolt to maximize the security of the lock

Punti di chiusura indipendenti: qualora venga forzato uno dei catenacci i restanti rimangono in posizione di blocco

Independent locking points: if one of the dead bolts is forced open the others stay closed

Montaggio cilindro a spillo

Cross key cylinder assembly

Cilindro a spillo cod. 4052 o 4052/1 con chiavi lunghe

Cross key cylinder cod. 4052 or 4052/1 (long keys)

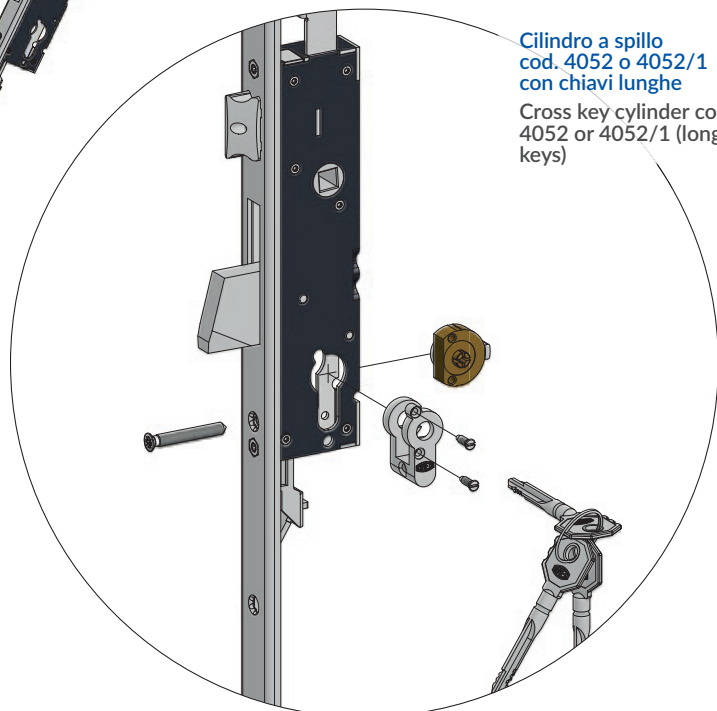

Attacco M8
 M8 Device

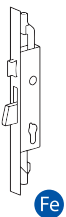

Serrature multipunto per montanti

Vertical multi-point locks



2 catenacci - 2 dead bolts

NEW

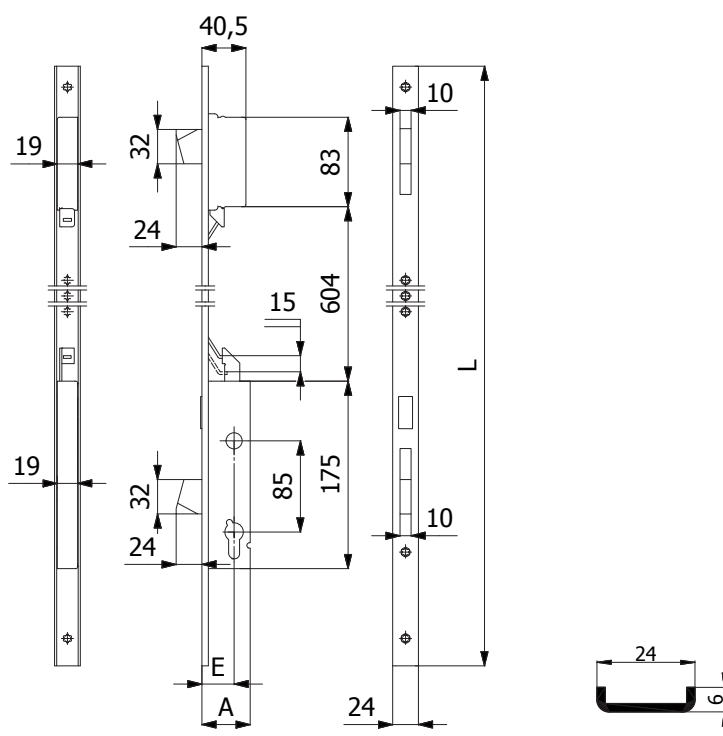
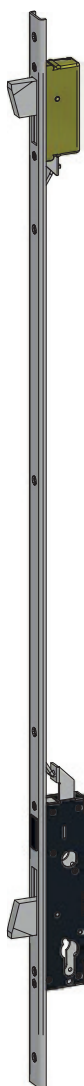

CARATTERISTICHE COSTRUTTIVE: Scatole e coperchi in acciaio zincato e plastificato - Catenacci autocentranti in lega speciale cromata con sistema anticasso.

FUNZIONAMENTO: Catenacci comandati dalla chiave.

MANO: Unica.

PARTI IN DOTAZIONE: 2 borchie cod. 0120 N, 2 sottofrontali cod. 0633 N, vite cilindro, viti di fissaggio in acciaio inox, istruzioni di montaggio.

CONSTRUCTIVE FEATURES: Zinc and plastic plated steel cases and covers - Chromed special alloy self-centering dead bolts with lock-picking system.

WORKING: Key driven dead bolts.

HAND: No hand.

PROVIDED WITH: 2 roses cod. 0120 N, 2 forend spacers cod. 0633 N, cylinder screw, stainless steel fixing screws, assembling instructions.

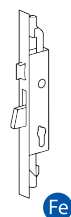

Fe

| COD. | NEW COD. | E | L | A | frontale forend | mandate throws | kg | | |
|--------|------------|----|------|----|---|-------------------|------|---|---|
| 1161/2 | 1531.25.UC | 25 | 1000 | 40 |  Acciaio inox Stainless steel | 1 | 1,10 | 5 | - |
| 1171/2 | 1531.30.UC | 30 | 1000 | 45 | | 1 | 1,13 | 5 | - |
| 1181/2 | 1531.35.UC | 35 | 1000 | 50 | | 1 | 1,16 | 5 | - |

Serrature multipunto per montanti

Vertical multi-point locks



2 catenacci 4 punti di chiusura - 2 dead bolts 4 locking points

Con attacchi M8 - Provided with M8 devices

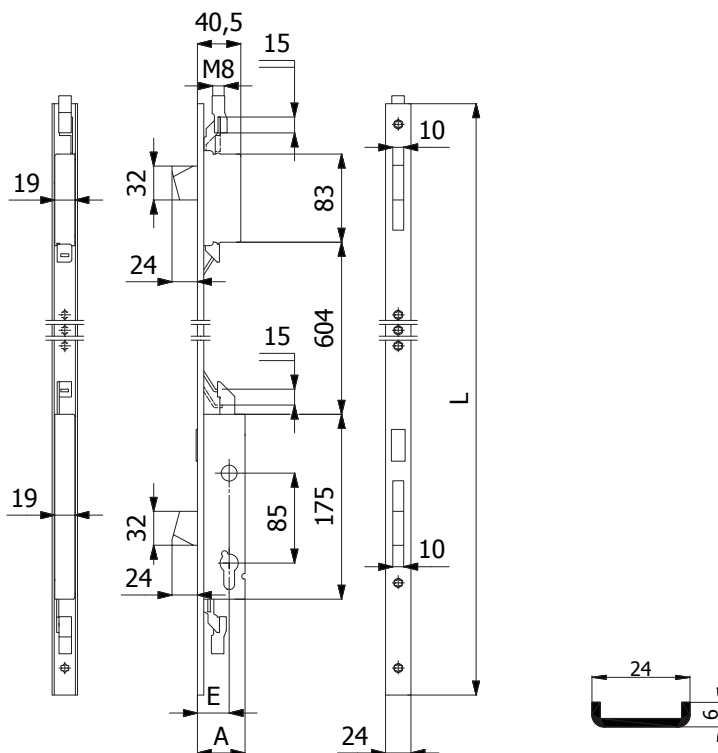
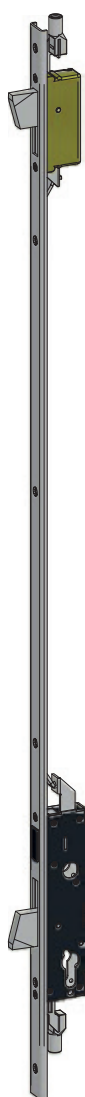

CARATTERISTICHE COSTRUTTIVE: Scatole e coperchi in acciaio zincato e plastificato - Catenacci autocentranti in lega speciale cromata con sistema antiscasso.

FUNZIONAMENTO: Catenacci comandati dalla chiave.

MANO: Unica.

PARTI IN DOTAZIONE: 2 borchie cod. 0120 N, 2 sottofrontali cod. 0633 N, vite cilindro, viti di fissaggio in acciaio inox, istruzioni di montaggio.

CONSTRUCTIVE FEATURES: Zinc and plastic plated steel cases and covers - Chromed special alloy self-centering dead bolts with lock-picking system.

WORKING: Key driven dead bolts.

HAND: No hand.

PROVIDED WITH: 2 roses cod. 0120 N, 2 forend spacers cod. 0633 N, cylinder screw, stainless steel fixing screws, assembling instructions.

| COD. | E | L | A | frontale forend | mandate throws | kg | | |
|---------------|----|------|----|-------------------------------------|-------------------|------|---|---|
| 1531.25.UC.M8 | 25 | 1000 | 40 | Acciaio inox Stainless steel | 1 | 1,16 | 5 | - |
| 1531.30.UC.M8 | 30 | 1000 | 45 | | 1 | 1,19 | 5 | - |
| 1531.35.UC.M8 | 35 | 1000 | 50 | | 1 | 1,22 | 5 | - |

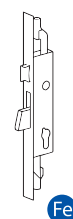

Fe

Serrature multipunto per montanti

Vertical multi-point locks



3 catenacci e scrocco regolabile 5 punti di chiusura - 3 dead bolts and adjustable latch bolt 5 locking points
 Con attacchi M8 - Provided with M8 devices

AD ESAURIMENTO
 END OF LINE

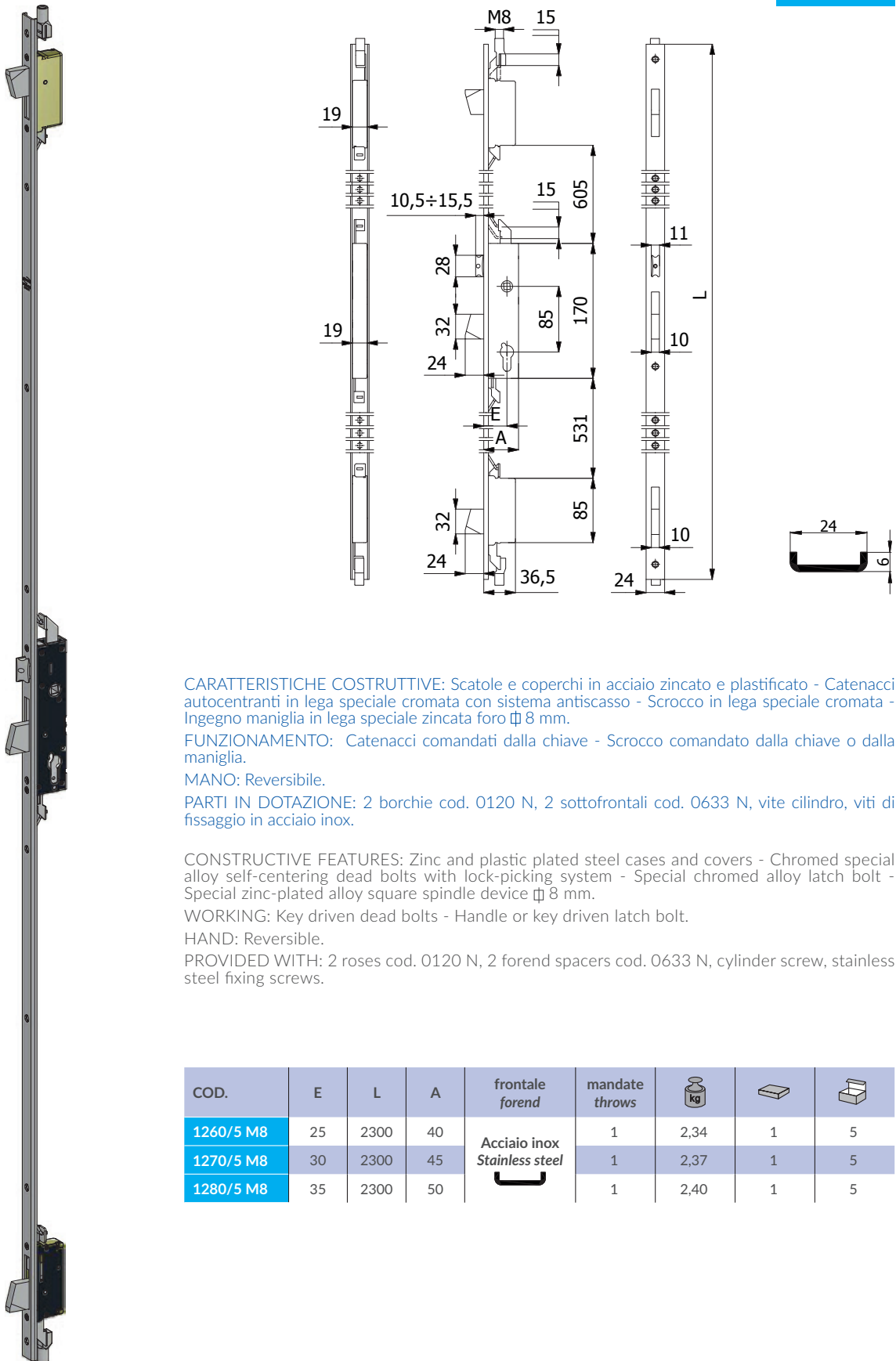

CARATTERISTICHE COSTRUTTIVE: Scatole e coperchi in acciaio zincato e plastificato - Catenacci autocentranti in lega speciale cromata con sistema antiscasso - Scrocco in lega speciale cromata - Ingegno maniglia in lega speciale zincata foro \varnothing 8 mm.

FUNZIONAMENTO: Catenacci comandati dalla chiave - Scrocco comandato dalla chiave o dalla maniglia.

MANO: Reversibile.

PARTI IN DOTAZIONE: 2 borchie cod. 0120 N, 2 sottofrontali cod. 0633 N, vite cilindro, viti di fissaggio in acciaio inox.

CONSTRUCTIVE FEATURES: Zinc and plastic plated steel cases and covers - Chromed special alloy self-centering dead bolts with lock-picking system - Special chromed alloy latch bolt - Special zinc-plated alloy square spindle device \varnothing 8 mm.

WORKING: Key driven dead bolts - Handle or key driven latch bolt.

HAND: Reversible.

PROVIDED WITH: 2 roses cod. 0120 N, 2 forend spacers cod. 0633 N, cylinder screw, stainless steel fixing screws.

| COD. | E | L | A | frontale forend | mandate throws | | | |
|-----------|----|------|----|--------------------|-------------------|------|---|---|
| 1260/5 M8 | 25 | 2300 | 40 | | 1 | 2,34 | 1 | 5 |
| 1270/5 M8 | 30 | 2300 | 45 | | 1 | 2,37 | 1 | 5 |
| 1280/5 M8 | 35 | 2300 | 50 | | 1 | 2,40 | 1 | 5 |

Serrature multipunto per montanti

Vertical multi-point locks



3 catenacci 5 punti di chiusura - 3 dead bolts 5 locking points

Con attacchi M8 - Provided with M8 devices

AD ESAURIMENTO
END OF LINE

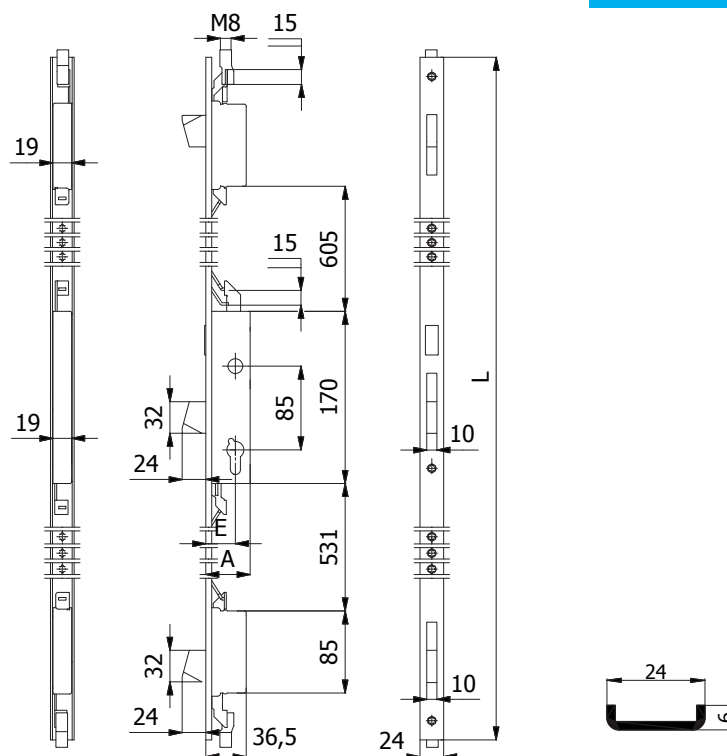

CARATTERISTICHE COSTRUTTIVE: Scatole e coperchi in acciaio zincato e plastificato - Catenacci autocentranti in lega speciale cromata con sistema antiscasso.

FUNZIONAMENTO: Catenacci comandati dalla chiave.

MANO: Unica.

PARTI IN DOTAZIONE: 2 borchie cod. 0120 N, 2 sottofrontali cod. 0633 N, vite cilindro, viti di fissaggio in acciaio inox.

CONSTRUCTIVE FEATURES: Zinc and plastic plated steel cases and covers - Chromed special alloy self-centering dead bolts with lock-picking system.

WORKING: Key driven dead bolts.

HAND: No hand.

PROVIDED WITH: 2 roses cod. 0120 N, 2 forend spacers cod. 0633 N, cylinder screw, stainless steel fixing screws.

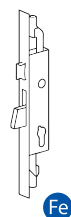

Fe

| COD. | E | L | A | frontale forend | mandate throws | kg | | |
|-----------|----|------|----|---------------------------------|-------------------|------|---|---|
| 1261/5 M8 | 25 | 2300 | 40 | Acciaio inox Stainless steel | 1 | 2,27 | 1 | 5 |
| 1271/5 M8 | 30 | 2300 | 45 | | 1 | 2,30 | 1 | 5 |
| 1281/5 M8 | 35 | 2300 | 50 | | 1 | 2,33 | 1 | 5 |

Serrature multipunto per montanti

Vertical multi-point locks



3 catenacci e scrocco regolabile 5 punti di chiusura - 3 dead bolts and adjustable latch bolt 5 locking points
 Con attacchi M8 - Provided with M8 devices

NEW

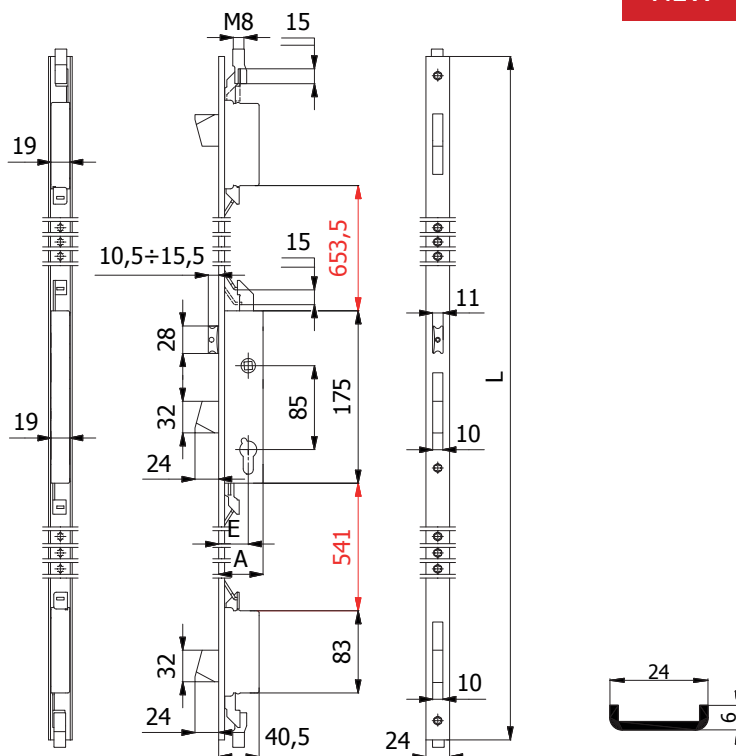
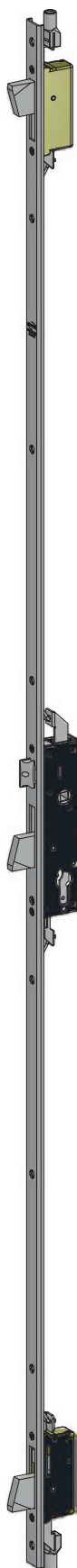

CARATTERISTICHE COSTRUTTIVE: Scatole e coperchi in acciaio zincato e plastificato - Catenacci autocentranti in lega speciale cromata con sistema anticasso - Scrocco in lega speciale cromata - Ingegno maniglia in lega speciale zincata foro \varnothing 8 mm.

FUNZIONAMENTO: Catenacci comandati dalla chiave - Scrocco comandato dalla chiave o dalla maniglia.

MANO: Reversibile.

PARTI IN DOTAZIONE: 2 borchie cod. 0120 N, 2 sottofrontali cod. 0633 N, vite cilindro, viti di fissaggio in acciaio inox.

CONSTRUCTIVE FEATURES: Zinc and plastic plated steel cases and covers - Chromed special alloy self-centering dead bolts with lock-picking system - Special chromed alloy latch bolt - Special zinc-plated alloy square spindle device \varnothing 8 mm.

WORKING: Key driven dead bolts - Handle or key driven latch bolt.

HAND: Reversible.

PROVIDED WITH: 2 roses cod. 0120 N, 2 forend spacers cod. 0633 N, cylinder screw, stainless steel fixing screws.

| NEW COD. | E | L | A | frontale forend | mandate throws | kg | | |
|--------------|----|------|----|---------------------------------|----------------|------|---|---|
| 1500.25.ULM8 | 25 | 2300 | 40 | Acciaio inox Stainless steel | 1 | 2,34 | 1 | 5 |
| 1500.30.ULM8 | 30 | 2300 | 45 | | 1 | 2,37 | 1 | 5 |
| 1500.35.ULM8 | 35 | 2300 | 50 | | 1 | 2,40 | 1 | 5 |

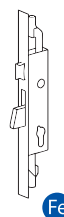

Fe

Serrature multipunto per montanti

Vertical multi-point locks



3 catenacci 5 punti di chiusura - 3 dead bolts 5 locking points
 Con attacchi M8 - Provided with M8 devices

NEW

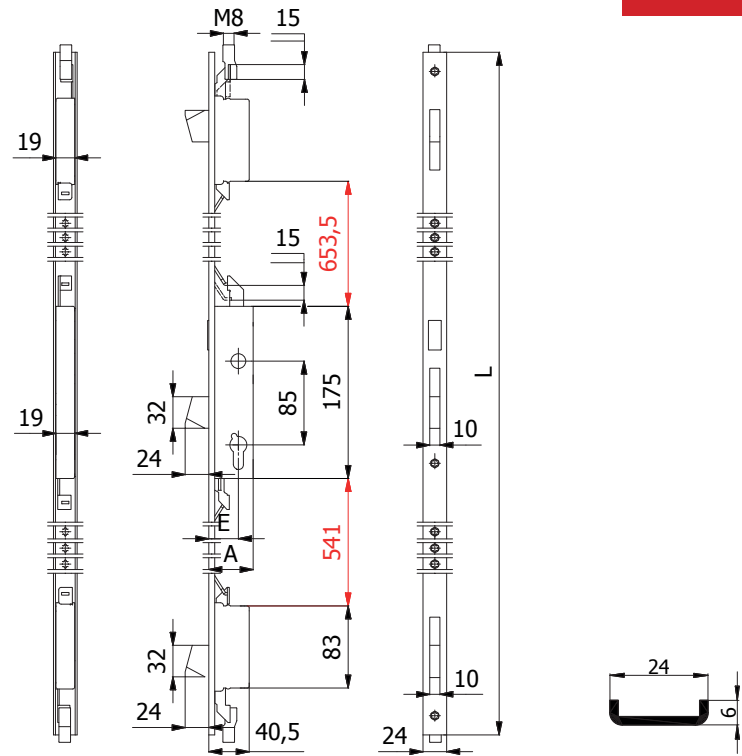

CARATTERISTICHE COSTRUTTIVE: Scatole e coperchi in acciaio zincato e plastificato - Catenacci autocentranti in lega speciale cromata con sistema antiscasso.

FUNZIONAMENTO: Catenacci comandati dalla chiave.

MANO: Unica.

PARTI IN DOTAZIONE: 2 borchie cod. 0120 N, 2 sottofrontali cod. 0633 N, vite cilindro, viti di fissaggio in acciaio inox.

CONSTRUCTIVE FEATURES: Zinc and plastic plated steel cases and covers - Chromed special alloy self-centering dead bolts with lock-picking system.

WORKING: Key driven dead bolts.

HAND: No hand.

PROVIDED WITH: 2 roses cod. 0120 N, 2 forend spacers cod. 0633 N, cylinder screw, stainless steel fixing screws.



Fe

| NEW COD. | E | L | A | frontale forend | mandate throws | kg | | |
|--------------|----|------|----|---------------------------------|----------------|------|---|---|
| 1501.25.ULM8 | 25 | 2300 | 40 | Acciaio inox Stainless steel | 1 | 2,27 | 1 | 5 |
| 1501.30.ULM8 | 30 | 2300 | 45 | | 1 | 2,30 | 1 | 5 |
| 1501.35.ULM8 | 35 | 2300 | 50 | | 1 | 2,33 | 1 | 5 |

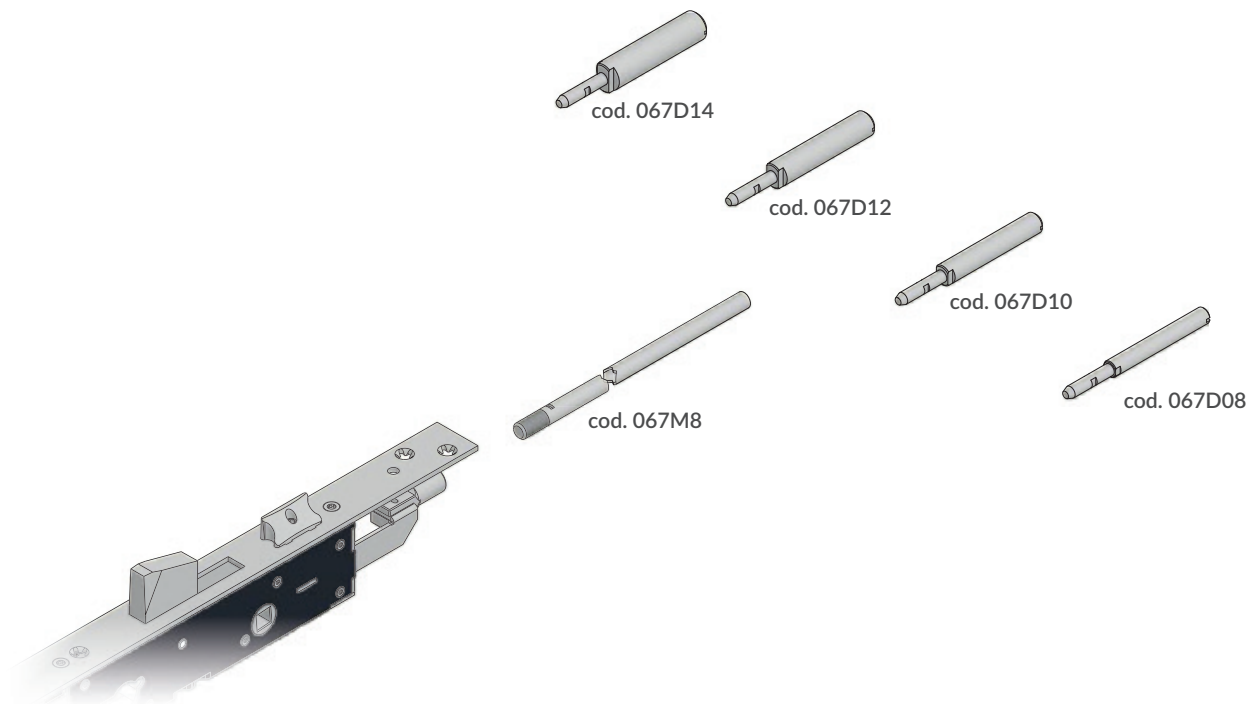

Asta interna con attacco M8
Internal rod with M8 device

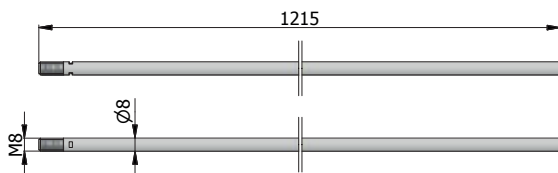

| COD. | Materiale - Material | kg | | |
|--------------|--------------------------------------|-------|----|---|
| 067M8 | Acciaio zincato Zinc-plated steel | 0.196 | 50 | - |

Puntale antisega
Steel-saw resistant tip

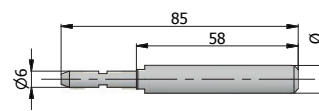

Per aste cod. 067M8
For rods cod. 067M8

| COD. | Materiale - Material | Ø | kg | | |
|---------------|---|----|-------|----|---|
| 067D08 | Acciaio cementato e zincato Hardened zinc-plated steel | 8 | 0,027 | 50 | - |
| 067D10 | Acciaio cementato e zincato Hardened zinc-plated steel | 10 | 0,040 | 50 | - |
| 067D12 | Acciaio cementato e zincato Hardened zinc-plated steel | 12 | 0,054 | 50 | - |
| 067D14 | Acciaio cementato e zincato Hardened zinc-plated steel | 14 | 0,072 | 50 | - |

